

RIXSON®

ASSA ABLOY

Troubleshooting The Product You Have

ASSA ABLOY, the global leader in door opening solutions

Contents

General Notes Before You Start:	
Heavy-Duty & Shallow Depth Floor Closers	p 3
Similarities of Single Acting Offset & Center Hung Floor Closers	p 6
Troubleshooting Offset Floor Closers	p 7
Troubleshooting Center Hung Floor Closers	p 12
Troubleshooting Overhead Concealed Floor Closers	p 19
Troubleshooting Checkmate [®] Holders & Stops	p 20
Troubleshooting Your Door Holder	p 21
Troubleshooting Smok Chek [®] V	p 22
Troubleshooting Smok Chek [®] VI	p 23

Supplemental Data

LOOK AT THE DOOR IN CLOSED POSITION FROM PULL SIDE OF DOOR

A. Is space between door, jamb, and sill consistent? *If sagging, need to determine if reinforcements have failed or product is installed incorrectly.*

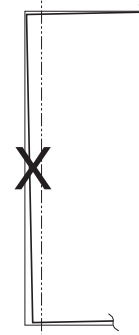

B. Is threshold worn from door dragging? *Remove arm cap and loosen arm locking screw. Remove intermediate pivot cap and turn the set screw to raise the door. Put shims under arm of closer (between arm and boss). Back-off set screw and replace cap on M19. Now door is resting on spindle again. Tighten arm locking bolt screw. Replace arm cap. *Does not apply to center hung closers*

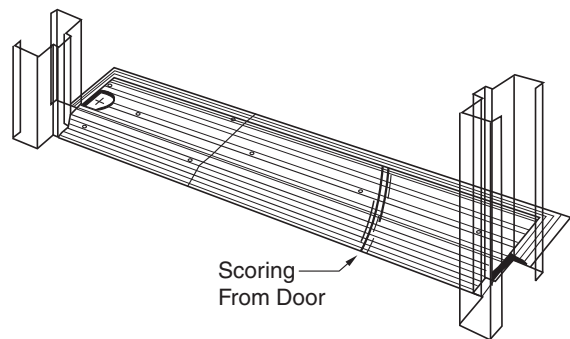

C. Are leaves of top pivot more than 3/16" apart? Can you move the top pivot up and down with your fingers? *The welds on the reinforcements have broken loose or were never there. Frames will need to be repaired before new product is installed.*

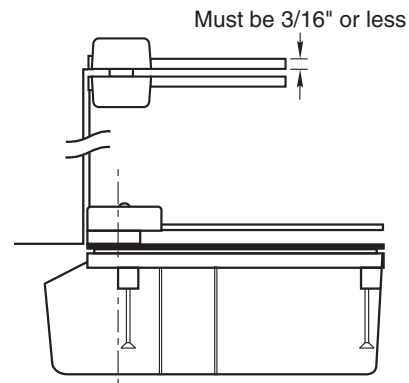

D. On offset installation, is there an intermediate pivot? What is the gap between the two leaves? *More than 3/16" or tight together presents problem. Weight of door should be on the bottom arm. No gap means intermediate pivot is carrying load of door.*

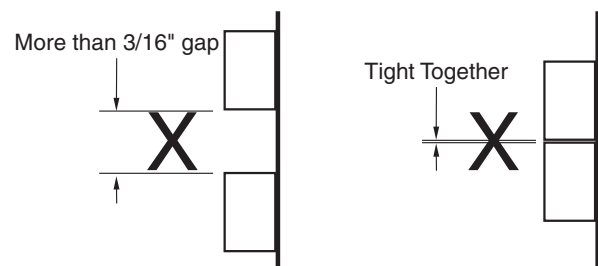

General Notes Before You Start: Heavy-Duty and Shallow Depth Floor Closers

Supplemental Data

LOOK AT THE DOOR IN CLOSED POSITION FROM PULL SIDE OF DOOR

E. Is door plumb? A variance of 1/8" voids warranty.

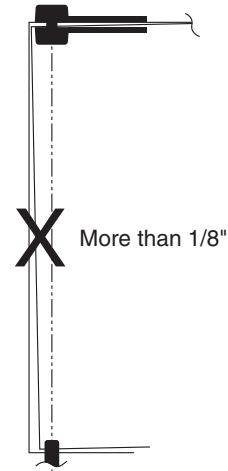

F. Remove arm cap and tighten arm on spindle. Repeat several times with door in the open and closed positions.

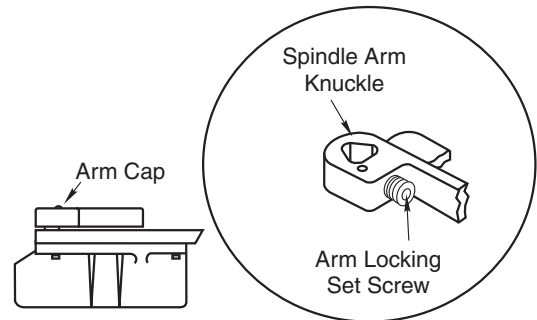

G. On Q27 and HM27 closers, make sure thru bolts are secure.

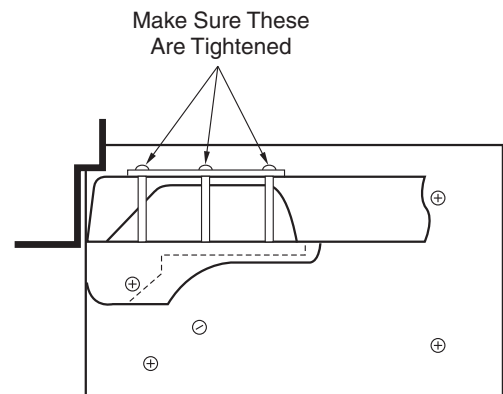

H. Are there any noticeable pressure conditions? Spring tension may need to be adjusted but, if too severe, may not be overcome.

Supplemental Data

LOOK AT THE DOOR IN CLOSED POSITION FROM PUSH SIDE OF DOOR

- A. Is there weatherstrip interference?** *Very critical. If it looks like there is a problem, have weatherstrip removed and see if closer works. If it does, then the owner will need to change weatherstrip type or location.*

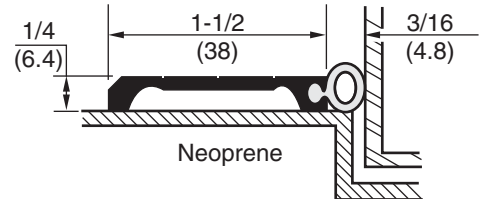

- B. Door with exit devices “bounces.”** *Disengage dogging. Closer will work fine. When using latching mechanisms, latch speed is faster than closing speed. When using push/pulls, the latch speed is slower so the door doesn't bounce. When exit devices are dogged, they are like a push/pull. Do not adjust to suit dogging. It may not close the door when latch is thrown.*

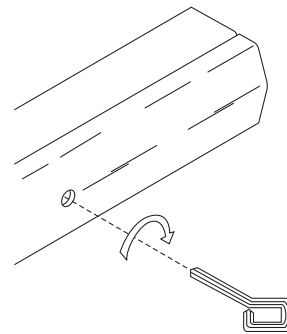

- C. Make sure all hardware latches and strikes align.** *Be aware of other hardware on the door that may be causing door not to close properly.*

OPEN THE DOOR AS FAR AS IT WILL GO

- A. Is degree of opening consistent with product specified or needed?** *i.e., Closer ordered with 90° hold open but trim hits the wall at 88°. Or, floor closer is 90° deadstop and Checkmate®'s templated at 110°. Top of door can be pushed, popping top pivot welds.*

- B. Do you feel backcheck at 70°?**
If not, make adjustments.



Backcheck valve

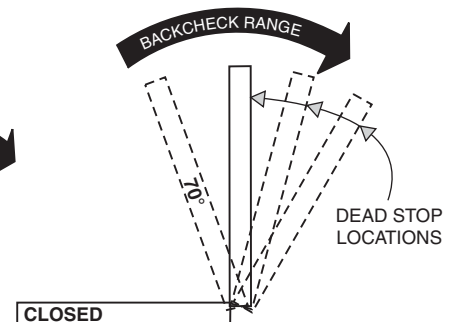

- C. Door should close from 90° to 0° in 3 to 6 seconds or longer.**

Similarities

Rixson heavy duty floor closers have springs that can be adjusted in the field. For aid in accomplishing this, contact a service center in your area. [Click here for End User Sales and Service Centers](#)

All Rixson single acting closers are handed. This is true of offset as well as center hung products.

Determining Hand of Door

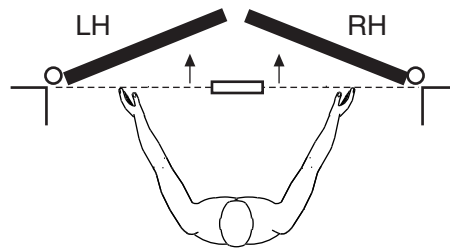

All Rixson single acting closers have a preloaded spindle that causes the arm (door) to come to rest beyond the zero degree position about 7° in towards the room. This is to make sure the latch engages in the strike and to help overcome negative building pressures. This requires all frames to have integral or applied stops.

Offset Installations

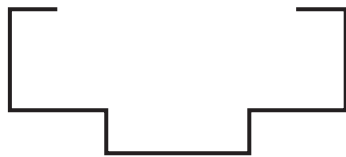

Rabbetted Frame

Center Hung Installations

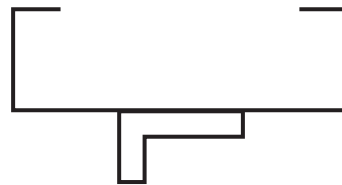

Cased Opening with Applied Stop

Offset Floor Closers

TROUBLE:

1. Door Will Not Fully Close

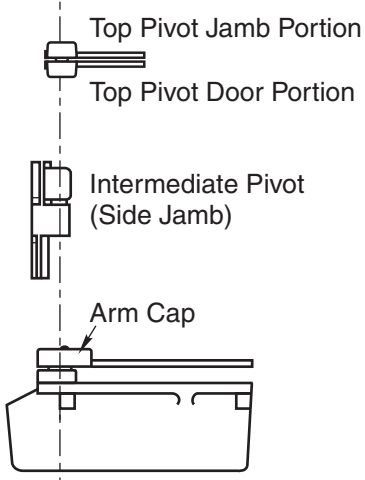
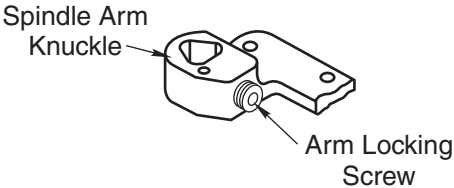
Probable Cause	Remedy
<p>A. Door is binding on head of frame, weatherstrip or jambs.</p>	<p>A. Check and correct alignment of top pivot, side jamb pivot and spindle. Check and correct closer location. Make certain closer is level and at proper depth. Check and correct mortising of arms and pivots. Move weatherstrip position on frame.</p> 
<p>B. Draft condition.</p>	<p>B. Adjust spring tension. <u>Note</u> winding spring will cause door to be harder to open. Attempt to decrease draft condition.</p>
<p>C. Arm loose on spindle.</p>	<p>C. Tighten arm locking screw.</p> 

2. Door Won't Close

Probable Cause	Remedy
<p>A. Broken internal mechanism.</p>	<p>A. Replace closer.</p>
<p>B. Spindle twisted from door racking. Improperly adjusted backcheck.</p>	<p>B. Replace closer.</p>

Offset Floor Closers

TROUBLE:

3. Door Opens Too Hard

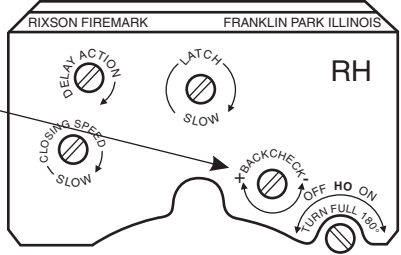
Probable Cause	Remedy
A. Too great a spring power.	A. Reduce spring tension.
B. Door is binding on head of frame weatherstrip or threshold.	B. Check and correct alignment of top pivot, side jamb pivot and spindle. Check and correct closer location. Make certain closer is level and at proper depth. Check and correct mortising of arms and pivots. Move weatherstrip position on frame.
C. Backcheck adjusted too firmly.	C. Release backcheck valve. (CCW) 

4. Door Closes Too Fast or Too Slow

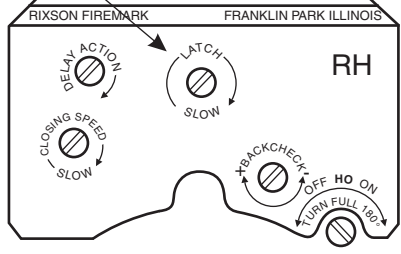
Probable Cause	Remedy
A. Closer requires adjustment.	A. On #20 and 25 closers, adjust the single valve in the center of the closer. Turn CW to slow down and CCW to make faster. On #27 and 51 closers, there are 2 closing speed valves: Stroke (from full open to 15°) and latch (from 15° to 0°). Turn CW to slow down and CCW to make faster. 

Offset Floor Closers

TROUBLE:

5. Door Closes Rapidly - No Control or Adjustment

Probable Cause	Remedy
A. Loss of hydraulics.	A. Remove floor plate. If evidence of leakage, replace closer.
B. Mechanical defect.	B. Replace closer.

6. Door Hits Dead Stop Too Hard - Racking Door (27 Only)

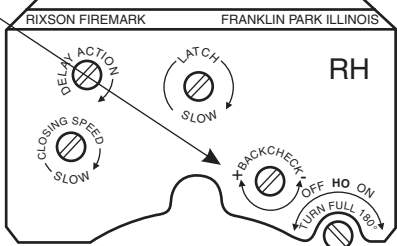
Probable Cause	Remedy
A. Backcheck not adjusted.	<p>A. Adjust hydraulic backcheck valve. <u>Note:</u> hydraulic backcheck must be adjusted to vary resistance from light to firm at 60° of door opening.</p> 

7. Door Cracks or Pops When Taken Out of Hold Open

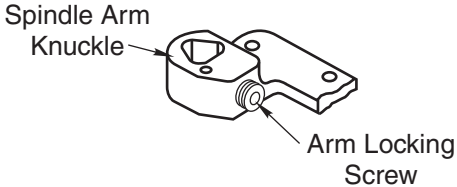
Probable Cause	Remedy
A. Arm locking screw loose.	<p>A. Tighten arm locking screw.</p> 

Offset Floor Closers

TROUBLE:

8. Door Drags On Floor or Threshold

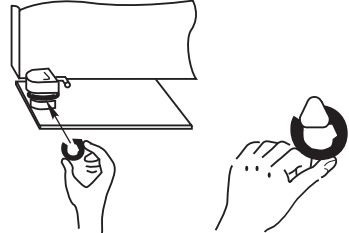
Probable Cause	Remedy
A. Arm locking screw loose.	A. Tighten arm locking screw.
B. Shims worn or missing.	B. Using intermediate pivot - raise door & re-insert shims. 

9. Arm Loose in Bottom of Door

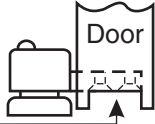
Probable Cause	Remedy
A. Arm screws not properly attached to door.	A. Tighten steel arm screws in bottom of door. Door must be reinforced. 

10. Hold Open Does Not Engage

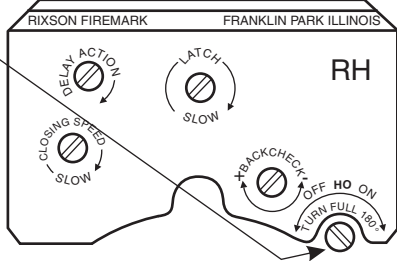
Probable Cause	Remedy
A. Closer is not hold open type.	A. Replace closer.
B. Selector hold open is not engaged (for 27 only).	B. Screw must be turned full 180°. 
C. Trim prevents door from reaching hold open point.	C. Reduce trim projection or replace closer with one that has a lesser hold open degree.

Offset Floor Closers

TROUBLE:

11. Door Wavers at Closed Position

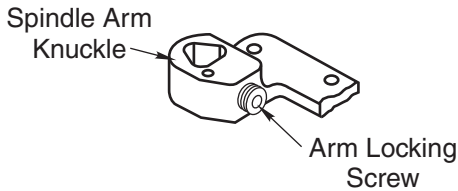
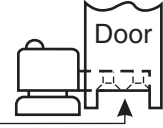
Probable Cause	Remedy
A. Arm locking screw is loose.	A. Tighten arm locking screw.  Spindle Arm Knuckle Arm Locking Screw
B. Arm screws not properly attached to door.	B. Tighten steel arm screws in bottom of door. Door must be reinforced.  Door

12. Door Slams Just Before Closing

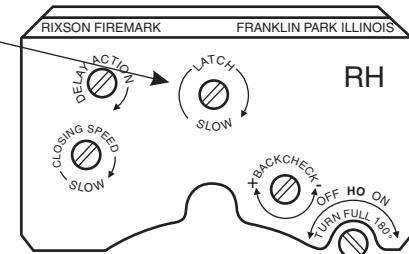
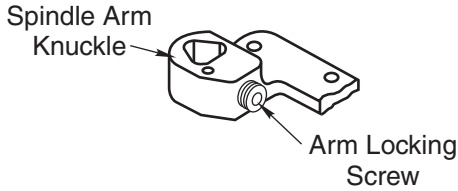
Probable Cause	Remedy
A. Latch valve requires adjustment.	A. Adjust latch valve. CW to slow, CCW to make faster.  RIXSON FIREMARK FRANKLIN PARK ILLINOIS RH DELAY ACTION LATCH SLOW CLOSING SPEED SLOW BACKCHECK OFF HO ON TURN FULL 180°
B. Arm locking screw is loose.	B. Tighten arm locking screw.  Spindle Arm Knuckle Arm Locking Screw

Center Hung Floor Closers

TROUBLE:

1. Door Will Not Fully Close

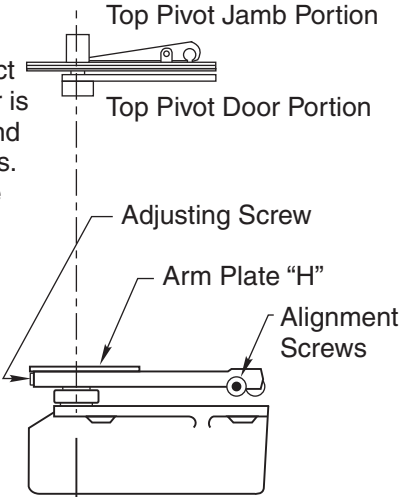
Probable Cause	Remedy
<p>A. Door is binding on head of frame, weatherstrip or jambs.</p>	<p>A. Check and correct alignment of top pivot and spindle. Check and correct closer location. Make certain closer is level and at proper depth. Check and correct mortising of arms and pivots. Minor horizontal adjustment can be made by turning arm screw.</p>  <p>The diagram illustrates the top pivot assembly of a center hung floor closer. It shows a cross-section of the door and jamb. Labels include: 'Top Pivot Jamb Portion' at the top, 'Top Pivot Door Portion' below it, 'Adjusting Screw' pointing to a screw on the side of the door, 'Arm Plate "H"' pointing to the horizontal arm, and 'Alignment Screws' pointing to screws on the end of the arm plate.</p>
<p>B. Draft condition.</p>	<p>B. Adjust spring tension. <u>Note</u> winding spring will cause door to be harder to open. Attempt to decrease draft condition.</p>
<p>C. Arm not properly centered.</p>	<p>C. Loosen and tighten arm alignment screws to center door.</p>

2. Door Is Racking Against Jamb

Probable Cause	Remedy
<p>A. Door allowed to hit jamb or wall.</p>	<p>A. Floor stop or holder required to prevent door from hitting jamb or wall.</p>

Center Hung Floor Closers

TROUBLE:

3. Door Opens Too Hard

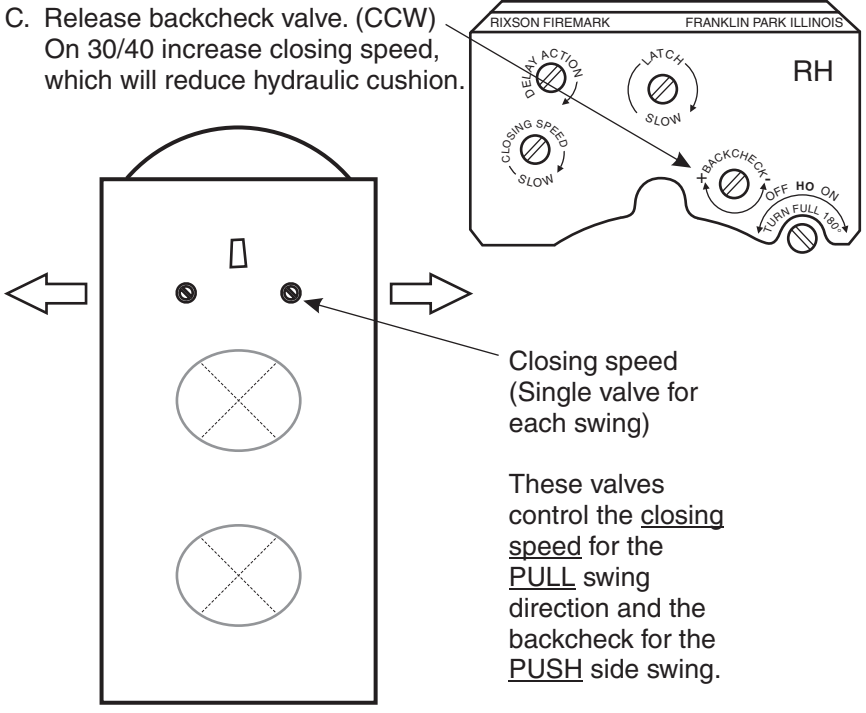
Probable Cause	Remedy
A. Too great a spring power.	A. Reduce spring tension.
B. Door is binding on head of frame weatherstrip or threshold.	B. Check and correct alignment of top pivot and spindle. Check and correct closer location. Make certain closer is level and at proper depth. Check and correct mortising of arms and pivots. Minor horizontal adjustment can be made by turning arm screw.
C. Backcheck or hydraulic cushion adjusted too firmly.	<p>C. Release backcheck valve. (CCW) On 30/40 increase closing speed, which will reduce hydraulic cushion.</p>  <p>Closing speed (Single valve for each swing)</p> <p>These valves control the <u>closing speed</u> for the <u>PULL</u> swing direction and the backcheck for the <u>PUSH</u> side swing.</p> <p><u>Models 30 and 40</u> (2 valves)</p>

Center Hung Floor Closers

TROUBLE:

4. Door Closes Too Fast or Too Slow

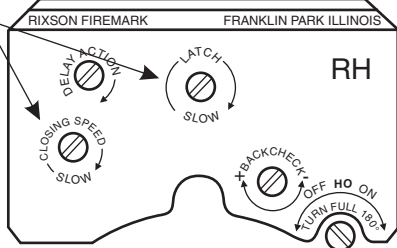
Probable Cause	Remedy
A. Closer requires adjustment.	<p>A. On #21 and 26 closers, adjust the single valve in the center of the closer. Turn CW to slow down and CCW to make faster. On #28 and 50 closers, there are 2 closing speed valves: Stroke (from full open to 15°) and latch (from 15° to 0°). Turn CW to slow down and CCW to make faster. On 30/40 series, independent valves control each swing. Turn CW to make faster.</p> 

5. Door Closes Rapidly - No Control or Adjustment

Probable Cause	Remedy
A. Loss of hydraulics.	A. Remove floor plate. If evidence of leakage, replace closer.
B. Mechanical defect.	B. Replace closer.

6. Door Hits Dead Stop Too Hard - Racking Door (28 Only)

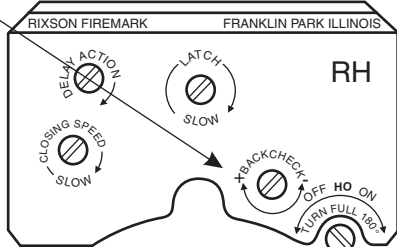
Probable Cause	Remedy
A. Backcheck not adjusted.	<p>A. Adjust hydraulic backcheck valve. <u>Note:</u> hydraulic backcheck must be adjusted to vary resistance from light to firm at 60° of door opening.</p> 

Center Hung Floor Closers

TROUBLE:

7. Door Cracks or Pops When Taken Out of Hold Open

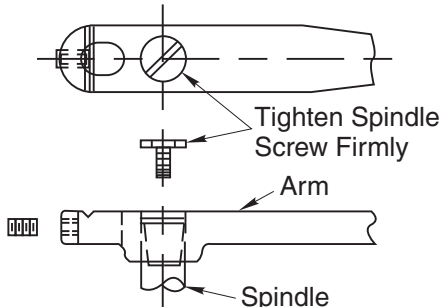
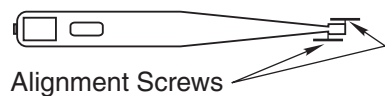
Probable Cause	Remedy
A. Spindle screw is loose.	A. Tighten spindle screw. 
B. Arm alignment screws loose, broken or missing.	B. Tighten arm alignment screws or replace with new. 
C. H-Plate loose on bottom web of door.	C. Remove door and re-affix H-Plate.

8. Door Drags On Floor or Threshold

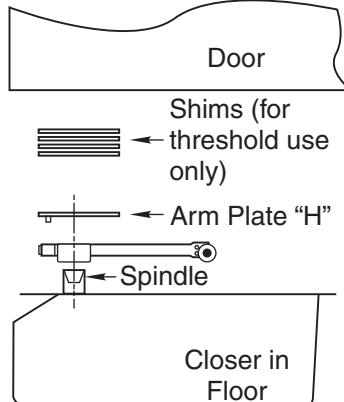
Probable Cause	Remedy
A. Requires vertical adjustment.	A. Remove door and insert shims between H plate & door rail to raise door. 
B. Closer set too deep or not level in floor.	B. Reset cement case to proper depth.

Center Hung Floor Closers

TROUBLE:

9. Arm Loose In Bottom of Door

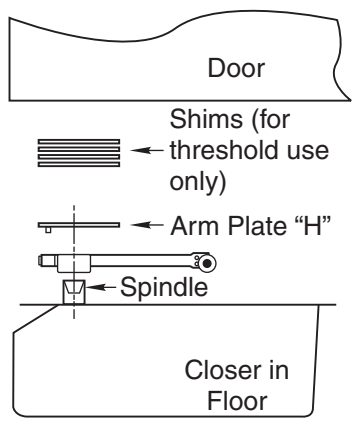
Probable Cause	Remedy
A. Arm alignment screws not properly tightened.	A. Tighten arm alignment screws.  Alignment Screws
B. Arm H plate not properly attached to door.	B. Tighten screws holding H plate. 

10. Hold Open Does Not Engage

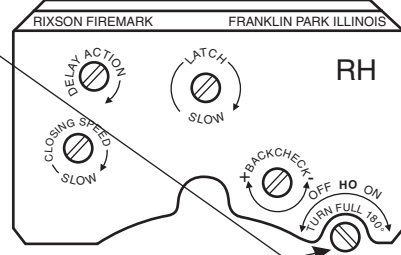
Probable Cause	Remedy
A. Closer is not hold open type.	A. Replace closer.
B. Selector hold open is not engaged (for 28 only).	B. Screw must be turned full 180°. 
C. Trim prevents door from reaching hold open point.	C. Reduce trim projection or replace closer with one that has a lesser hold open degree.



Center Hung Floor Closers

TROUBLE:

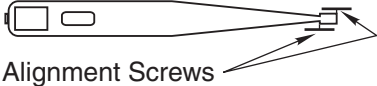
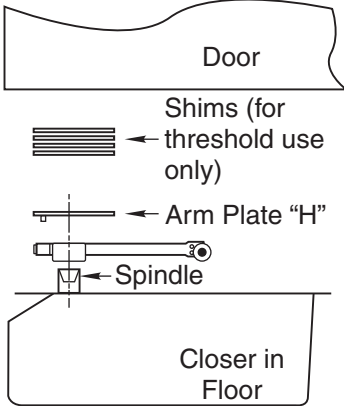
11. Door Wavers at Closed Position

Probable Cause	Remedy
A. Arm alignment screws are loose.	A. Tighten arm alignment screws. 
B. Arm H plate not properly attached to door. C. Arm H plate not properly attached to door.	B. Tighten screws holding H plate. C. Check and correct Arm H plate attachment to door. 

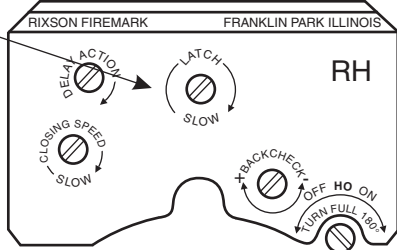
12. Door Slams Just Before Closing

Probable Cause	Remedy
A. Latch valve requires adjustment.	A. Adjust latch valve. CW to slow, CCW to make faster. 
B. Arm alignment screws are loose.	B. Tighten arm alignment screw. 

Center Hung Floor Closers

TROUBLE:

13. Door Swings Past Center

Probable Cause	Remedy
A. No stop on frame.	A. All single acting closers have preload on the spindle that causes the arm to rest at about 7° past center. Frame stop must be applied at lock edge, such as 60131.

14. Door Won't Close

Probable Cause	Remedy
A. Broken internal mechanism.	A. Replace closer.
B. Spindle twisted from door racking. Improperly adjusted backcheck.	B. Replace closer.

TO REMOVE CENTER HUNG DOOR
Does not apply to #26, 30 or 40 Closers

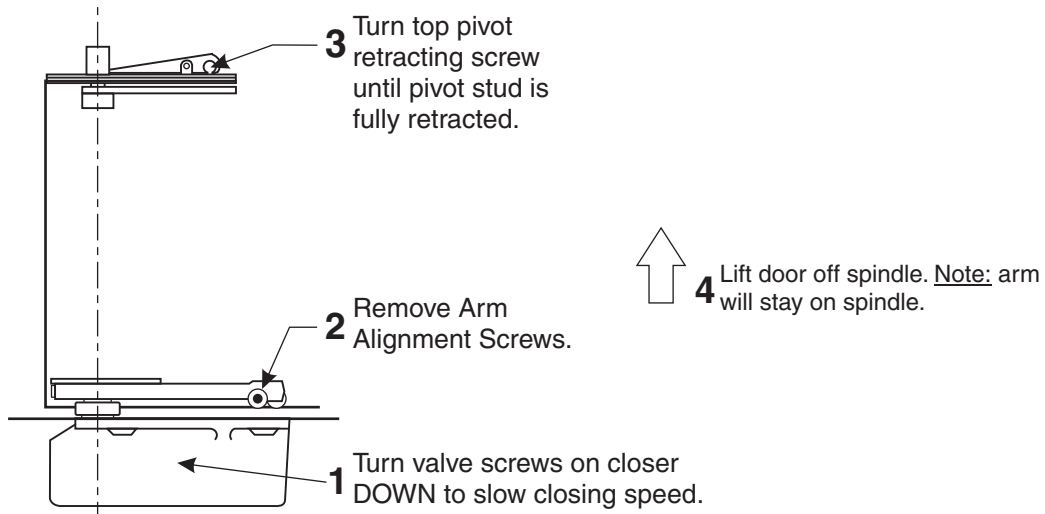

Overhead Concealed

TROUBLE:

1. Closer Leaking at Spindle

Probable Cause	Remedy
A. Door pushed past spindle stop.	A. Replace closer. Make sure there is an auxiliary stop.
B. Spindle seal worn.	B. Replace closer. Make sure there is an auxiliary stop.

2. Center Hung Arm Broken at Spindle

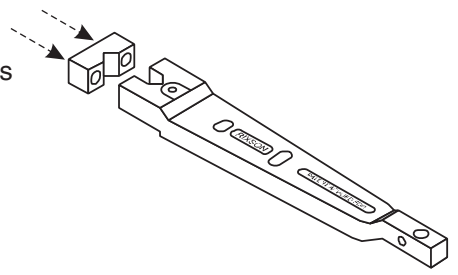
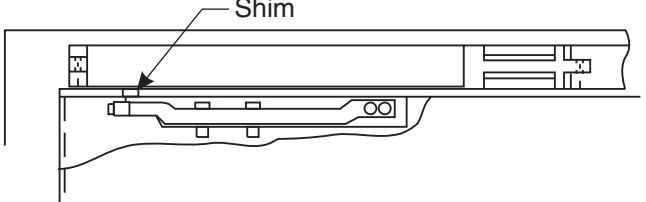
Probable Cause	Remedy
A. The screws were not tightened correctly when installed.	<p>A. When installing, do not tighten one side of spindle first. Always tighten evenly.</p> 
B. Arm mortise too deep. Won't allow complete engagement of spindle into arm.	<p>B. Shim arm.</p> 





Checkmate® Holders and Stops

TROUBLE:

1. Arm Drags

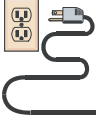
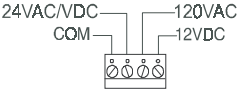
Probable Cause	Remedy
A. Templating is off. Arm is at an angle.	A. Re-mortise door.

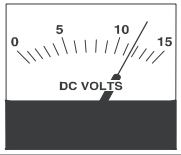
Troubleshooting Your Door Holder

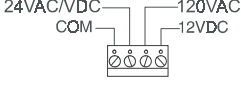
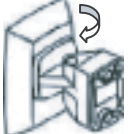
Problem	Possible Cause	
Does not Hold		Power not turned on.
		Ground wire not connected to "COM" on terminal strip. Power wire not connected to correct power slot on terminal strip.
		For single voltage coils—one wire attaches to ground, the other is attached to the power wire.
		Contact plate is not sitting completely flat across circular ring of the coil.
		Check line voltage coming from power supply (range +/-10%).
Holding Force Weak (less than 25 pounds)		For DC coils reverse polarity. Switch position of wires on terminal strip. Dirt or cleaning solvent on contact plate or on circular ring of coil; <i>wipe with very fine emery cloth with power turned off. Then clean surface again.</i>
		Power wire not connected to <u>correct</u> power slot on terminal strip. 12VAC input instead of 12VDC.
Humming Sound		Contact plate not sitting completely flat across the circular ring of the coil. Tighten armature pivoting screw.

Smok Chek® V

Checklist:

1. Make sure unit is connected to power.
2. Using piece of metal, insert in front of coil to see if it is operational. If not, recheck wiring and see where line is broken.
3. Check amperage draw. If multiple units are off one power supply, test each unit without the other units energized.
4. Verify dimensions from template.
5. Wires should be coming through frame away from the hinge.
6. If closer is mounted on push side of the door, reveal cannot be more than 3-1/2". For dimensions between 3-1/2" and 5-1/2" use 550789 arm. Over 5-1/2" there is no solution.
7. If closer is mounted on pull side of the door, reveal cannot be more than 1/8".

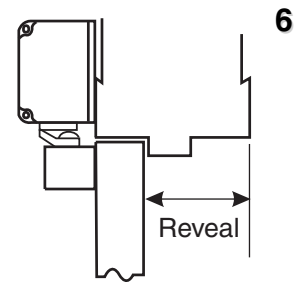
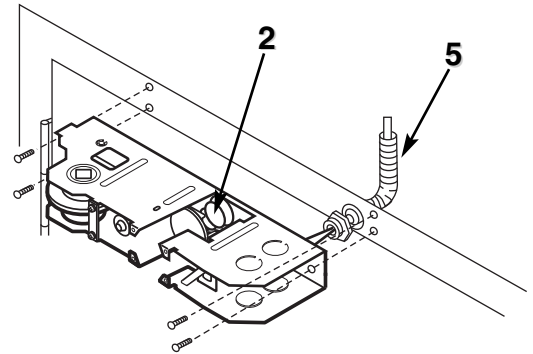

8. Remove cover from holder. With door in the open position, look up in "window". You should see the words "push" or "pull". If you are standing on the push side of the door you need to see the word "push" through the window.

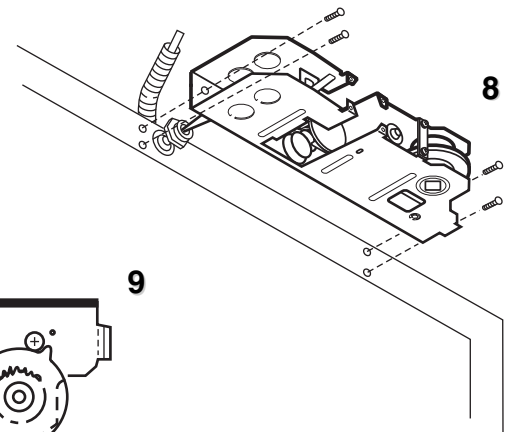

9. To strengthen hold, tighten or loosen adjusting nut.

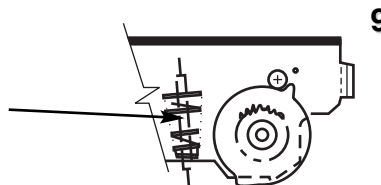

10. Arm should not have been pre-loaded.

11. Closers are set to lowest opening force possible from the factory. Do not increase spring power until holder is operational.

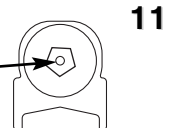

12. Verify arm length on sleeve.



13. Can door swing past 85°?

Smok Chek® VI

Checklist:

1. Make sure unit is connected to power.
2. Check templating.
3. Door must be able to swing 10°-15° past hold open point. If door cannot swing at least 100° it will not hold open (hold open range is 85°-170°).

4. Deep reveals on the pull side require a special arm.

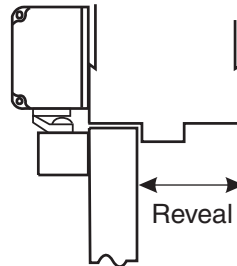

5. Door creeps shut - open door, hold in place, remove backcheck valve. Two or three drops of oil will drip out. Replace valve. Allow door to complete closing cycle. Open door to desired location. Allow door to close, open again and allow to close.

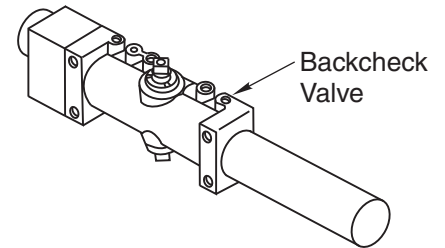

6. If door will not hold at all, gently turn solenoid CCW until door holds. Do not turn too much or door will not close at all.

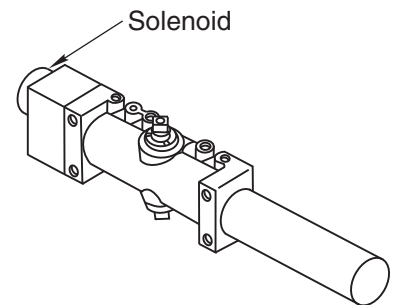

Rixson • 9100 West Belmont Avenue • Franklin Park, IL 60131 USA • Tel: 800.457.5670 • Fax: 800.221.0489 • www.rixson.com

Rixson® and Rixson and Design® are registered trademarks of Yale Security, Inc. Other products' brand names may be trademarks or registered trademarks of their respective owners and are mentioned for reference purposes only. These materials are protected under U.S. copyright laws. All contents current at time of publication. Copyright© 2008, Yale Security, Inc. All rights reserved. Reproduction in whole or in part without the express written permission of Yale Security, Inc. is prohibited.

ASSA ABLOY is the global leader in door opening solutions, dedicated to satisfying end-user needs for security, safety and convenience.